

CLEARANCE TABLE

1-WALL	2-WALL	3-WALL
4'	ONE AT 4' AND ONE AT 18'	CONSULT FACTORY

• IN APPLICATION WHERE THE UNIT IS CENTERED INSIDE AN OPEN STRINGER STYLE STAIRCASE, THE CLEARANCE TABLE CAN BE IGNORED PROVIDED THAT THE MINIMUM DIMENSION USED TO ACCOMMODATE THE UNIT INSIDE THE STAIRCASE IS THE SAME AS THE PIT RING. THE STAIRCASE MUST BE OPEN ON ALL FLOORS (INCLUDING LOWER FLOOR) ON ALL 4 SIDES OF THE UNIT. REFER TO PLANNING GUIDE FOR MORE DETAILS.

• THE UNIT CANNOT SERVER AS A FALL BARRIER. A HANDRAIL IS REQUIRED ON THE INTERIOR OF THE STAIRCASE.

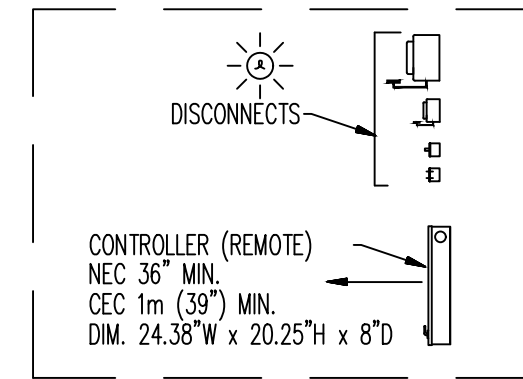

TYPE 2 CAR

DISCONNECTS AND CONTROLLER (REMOTE)

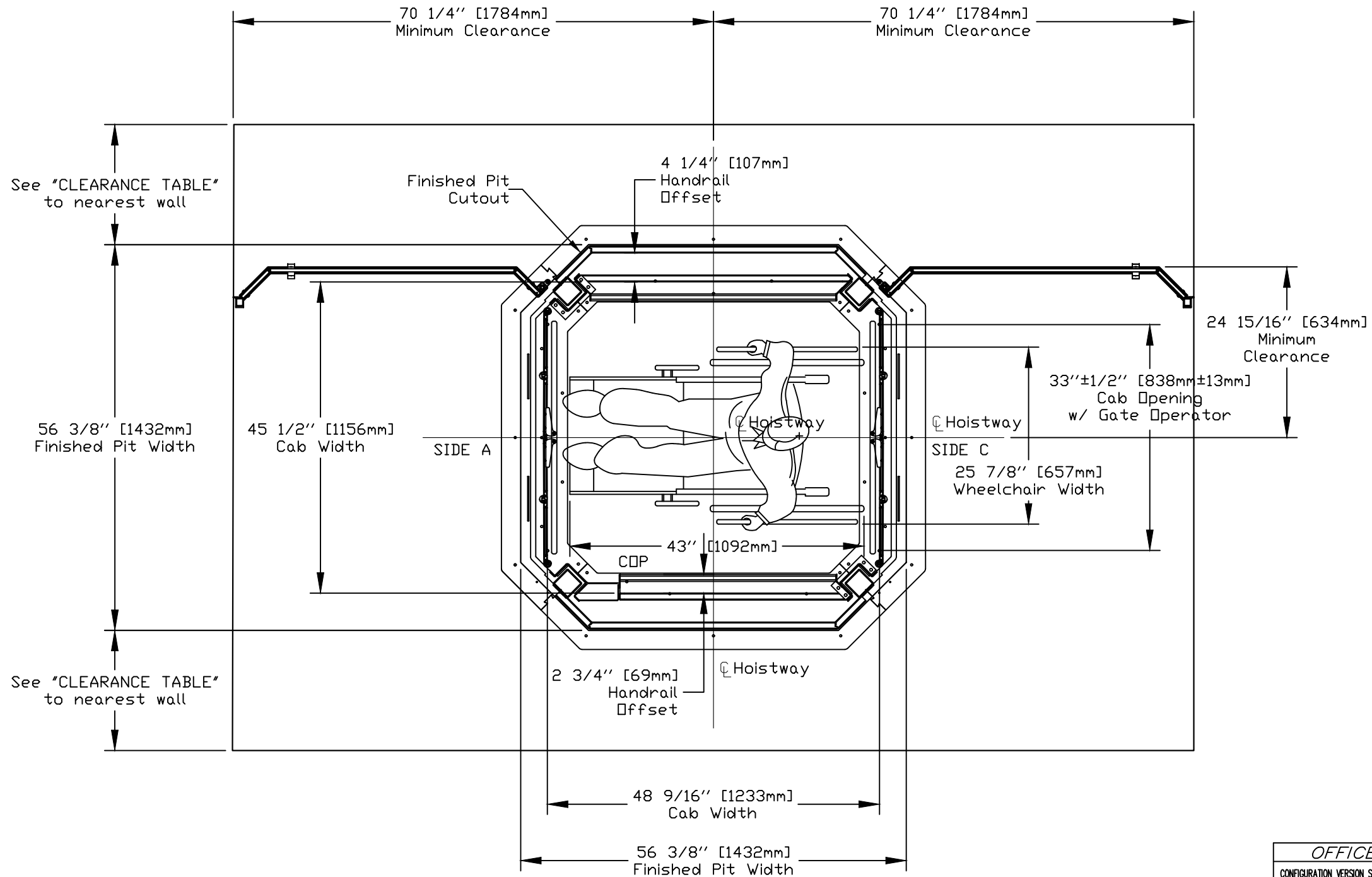

OFFICE USE ONLY:	
CONFIGURATION VERSION STAMP:	1.5
MODULE VERSION STAMP:	VUE_1.1.2

Part No.	Octagonal+ Glass
Variant No.	

CUSTOMER:	DATE:
PROJECT:	REVISION DATE:
ADDRESS:	COMPLETED BY:
	JOB No.

savaria

SHEET No. 1 OF 1

PLAN VIEW - TYPE 2 CAR

CLEARANCE TABLE

1-WALL	2-WALL	3-WALL
4'	ONE AT 4' AND ONE AT 18'	CONSULT FACTORY

- IN APPLICATION WHERE THE UNIT IS CENTERED INSIDE AN OPEN STRINGER STYLE STAIRCASE, THE CLEARANCE TABLE CAN BE IGNORED PROVIDED THAT THE MINIMUM DIMENSION USED TO ACCOMMODATE THE UNIT INSIDE THE STAIRCASE IS THE SAME AS THE PIT RING. THE STAIRCASE MUST BE OPEN ON ALL FLOORS (INCLUDING LOWER FLOOR) ON ALL 4 SIDES OF THE UNIT. REFER TO PLANNING GUIDE FOR MORE DETAILS.
- THE UNIT CANNOT SERVER AS A FALL BARRIER. A HANDRAIL IS REQUIRED ON THE INTERIOR OF THE STAIRCASE.

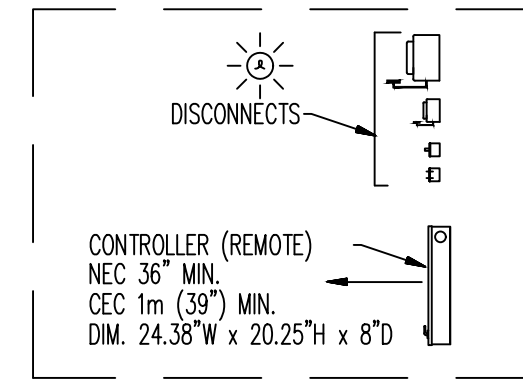

DISCONNECTS AND CONTROLLER (REMOTE)

TYPE 3R CAR

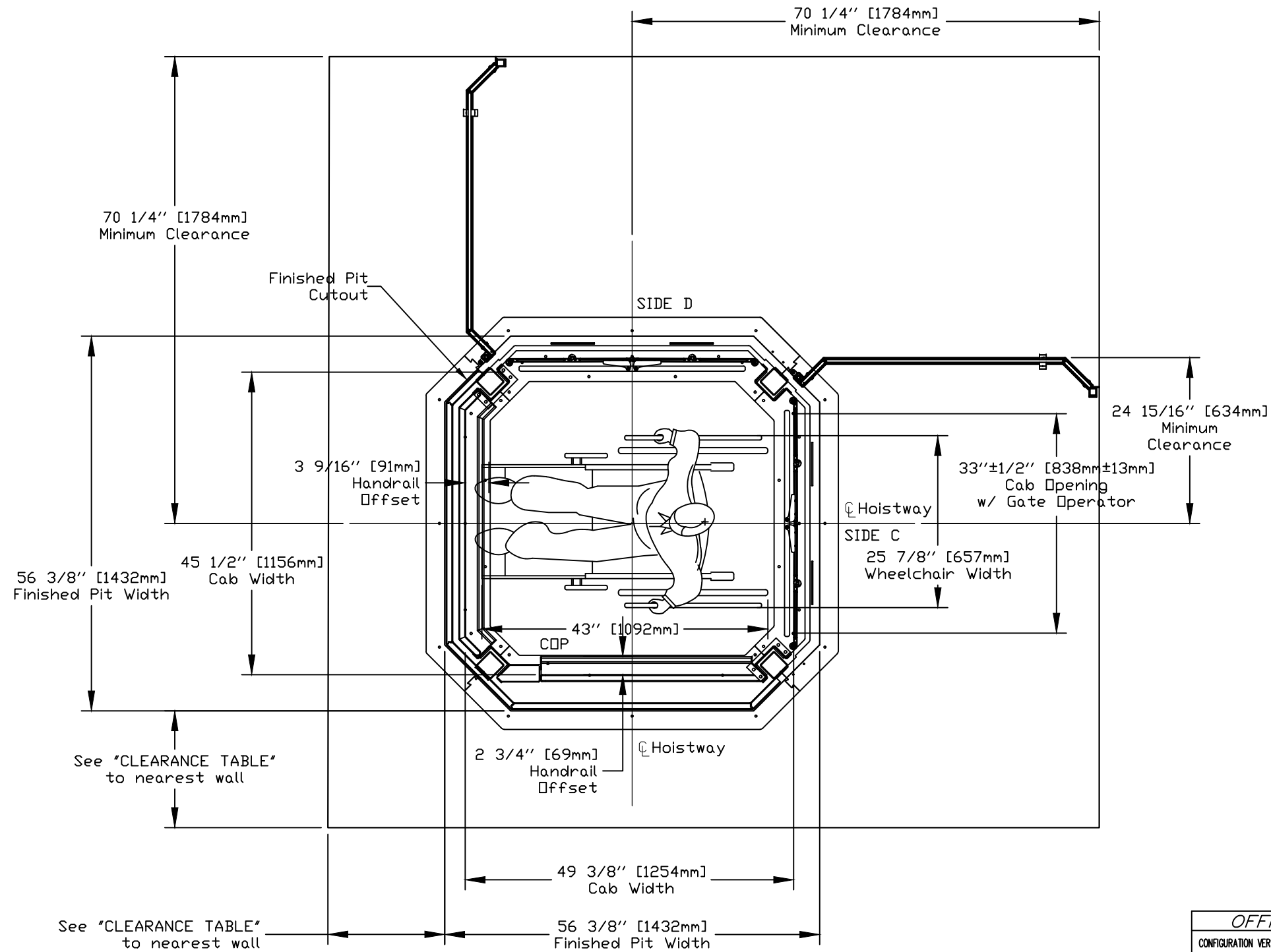

OFFICE USE ONLY:	
CONFIGURATION VERSION STAMP:	1.5
MODULE VERSION STAMP:	VUE_1.1.2

Part No.	Octagonal+ Glass
Variant No.	

CUSTOMER:	DATE:
PROJECT:	REVISION DATE:
ADDRESS:	COMPLETED BY:
	JOB No.
	SHEET No.



PLAN VIEW - TYPE 3R CAR